

ΤΕΧΝΙΚΕΣ ΠΡΟΔΙΑΓΡΑΦΕΣ / TECHNICAL SPECIFICATIONS / Технически спецификации

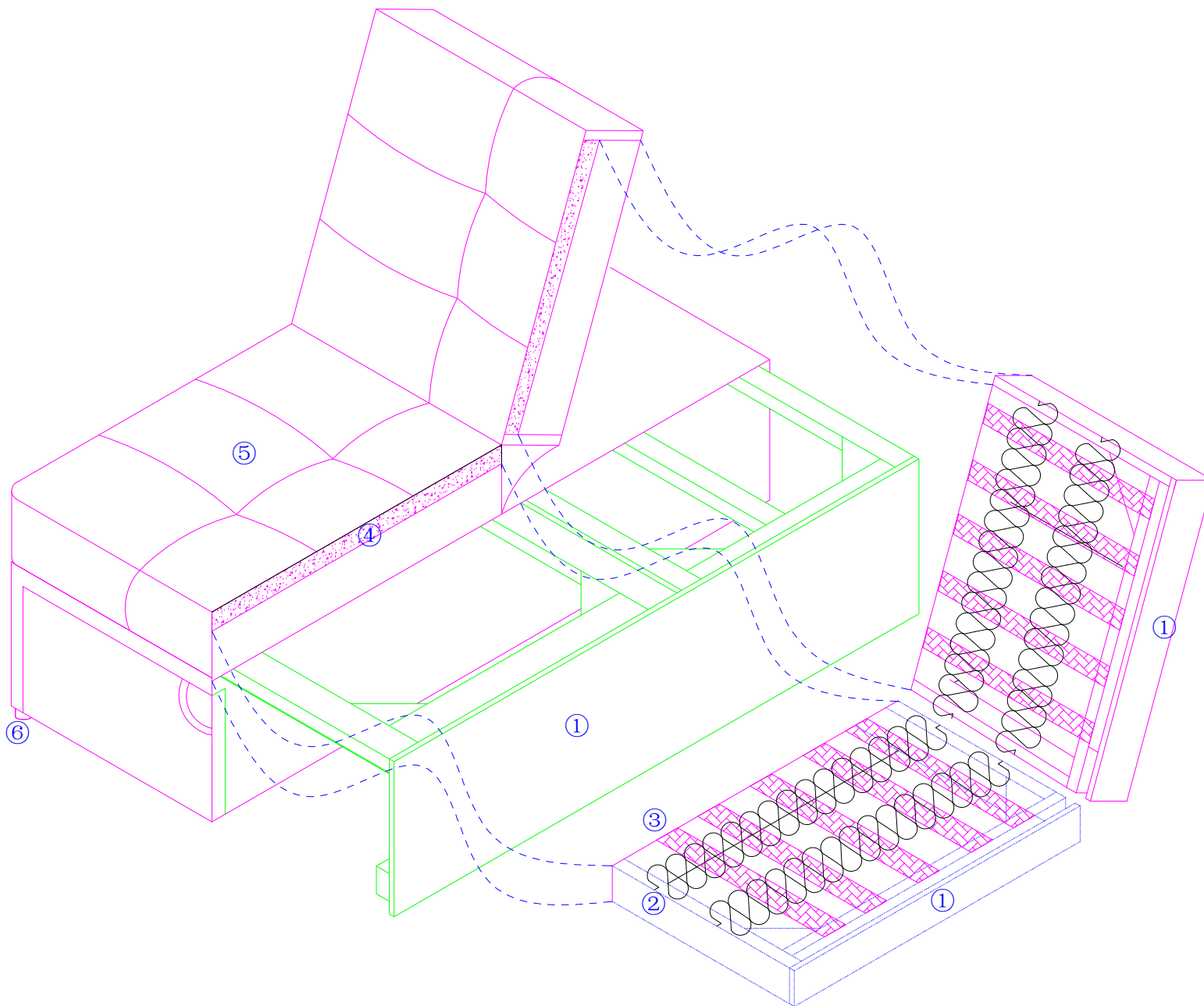





- 1) ΣΚΕΛΕΤΟΣ ΑΠΟ ΞΥΛΟ ΠΕΥΚΟΥ
- 2) ΕΛΑΤΗΡΙΑ POCKET SPRING SYSTEM
- 3) ΕΛΑΣΤΙΚΟΙ ΙΜΑΝΤΕΣ ΠΛΑΤΟΥΣ 4CM
- 4) ΑΦΡΩΔΕΣ ΥΛΙΚΟ ΠΥΚΝΟΤΗΤΑΣ 45 ΚΑΙ 20DNS
- 5) ΥΦΑΣΜΑ 100% ΠΟΛΥΕΣΤΕΡΙΚΗ ΙΝΑ
- 6) ΜΑΥΡΑ ΠΛΑΣΤΙΚΑ ΠΟΔΙΑ

- 1) PINE WOOD FRAME
- 2) POCKET SPRING SYSTEMS
- 3) ELASTIC STRAPS 4CM WIDE
- 4) FOAM DENSITY 45 AND 20DNS
- 5) FABRIC 100% POLYESTER FIBER
- 6) BLACK PLASTIC LEGS

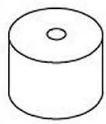
- 1) Рамка от дърво
- 2) Джобове с пружинните системи
- 3) Еластични каишки с ширина 4 см
- 4) Материал с плътност на пяната 45 и 20 dns
- 5) Състав 100% полиестерър
- 6) Черни пластмасови крака

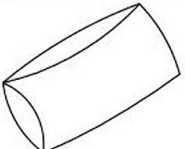
ΟΔΗΓΙΕΣ ΣΥΝΑΡΜΟΛΟΓΗΣΗΣ / ASSEMBLING INSTRUCTIONS / Инструкция за сглобяване

 A.4χ	 B.4χ	 E.2χ
 5CM C.4χ	 2.5CM D.12χ	

1:

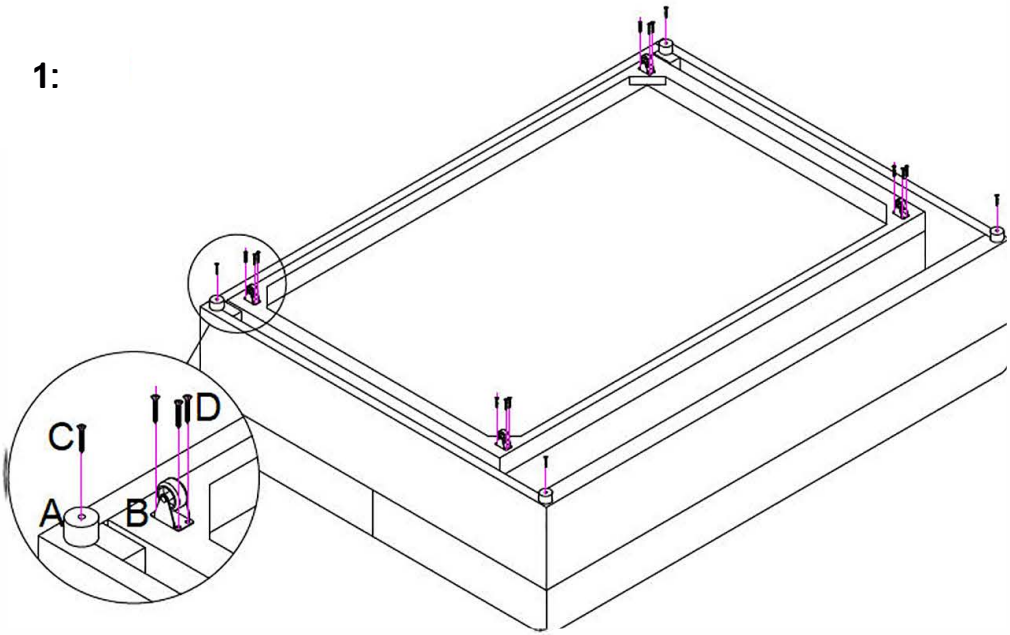

2:

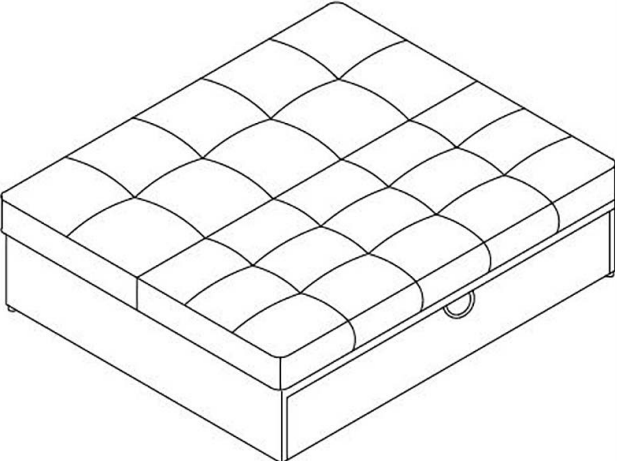

3:

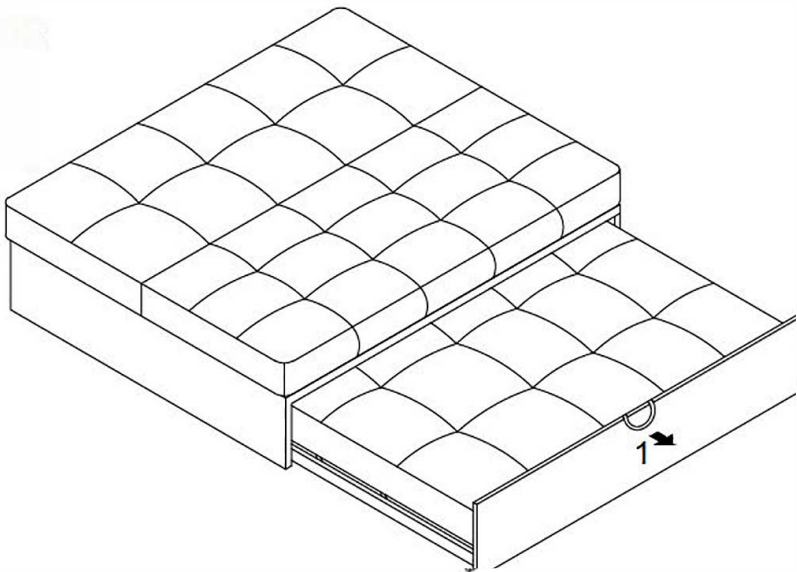

4:

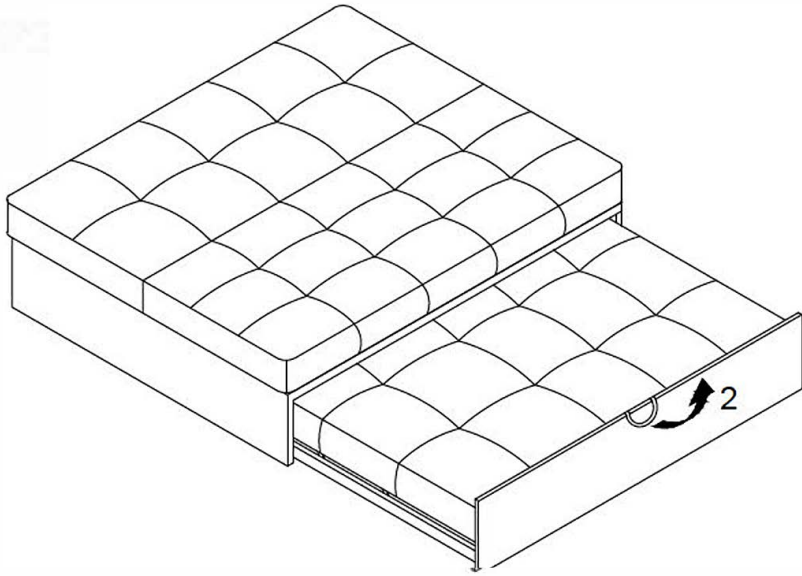

5:

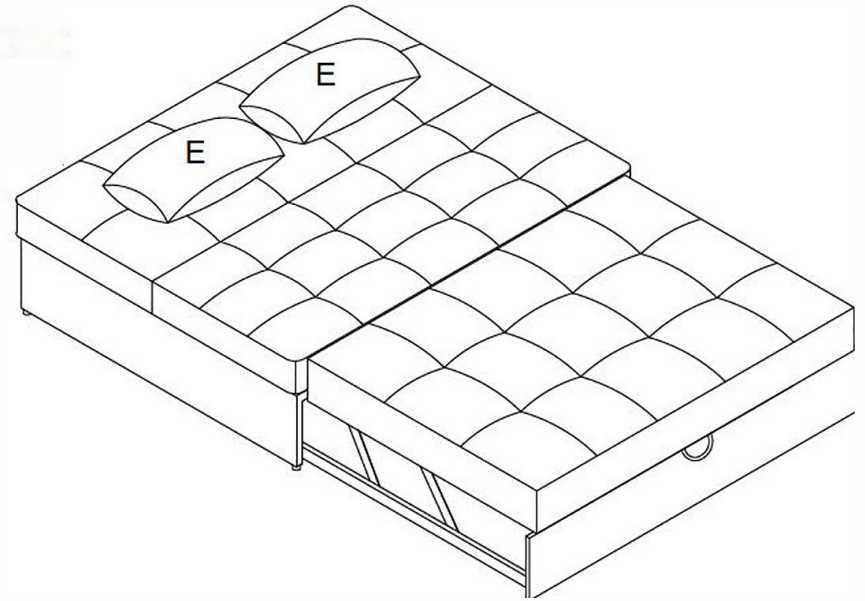

6:

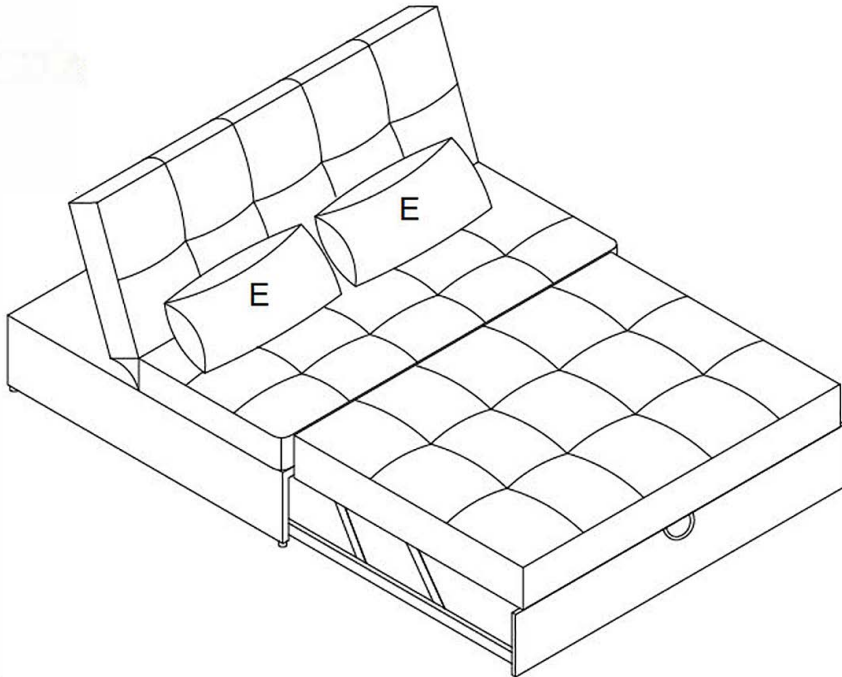

7:

