

ASSEMBLY INSTRUCTIONS/ΟΔΗΓΙΕΣ ΣΥΝΕΡΜΟΛΟΓΗΣΗΣ







CAUTIONS/ΠΡΟΣΟΧΗ:

1. Do not **FULLY-TIGHTEN** the nuts or nut bolts until all are in place./ Μη σφίγγετε εξ' ολοκλήρου τις βίδες και τα παξιμάδια μέχρι όλα να είναι σε θέση.

2. To prevent thread damage. Ensure that nuts or nut bolts are not over-tightened./ Για να αποφύγετε τη ζημιά του σπειρώματος βεβαιωθείτε ότι τα παξιμάδια ή τα περικόχλια δεν είναι υπερβολικά σφιγμένα.

3. Hardware is to be kept out of reach of children./ Τα παρελκώμενα πρέπει να φυλάσσονται μακριά από παιδιά.

PARTS/ΜΕΡΗ		
A	CUSHION BACK/ΚΑΘΙΣΜΑ	1
B	BACK VENEER/ΞΥΛΟ ΠΛΑΤΗΣ	1
C	FRONT LEG (L & R)/ ΜΠΡΟΣΤΙΝΟ ΠΟΔΙ	2
D	BACK LEG/ΠΙΣΩ ΠΟΔΙ	2
8	M4 X 16mm	 2
9	M5 X 32mm	 2
10	C99 M6 x 16mm	 4

HARDWARES/ΠΑΡΕΛΚΟΜΕΝΑ		
1	JCBC M6 x 35MM	 4
2	JCBC M6 x 40MM	 4
3	1/4"	 8
4	1/4"	 4
5	M4	 1
6	10.5mm	 2
7	14.5mm	 4

STEP 1/ΒΗΜΑ 1:

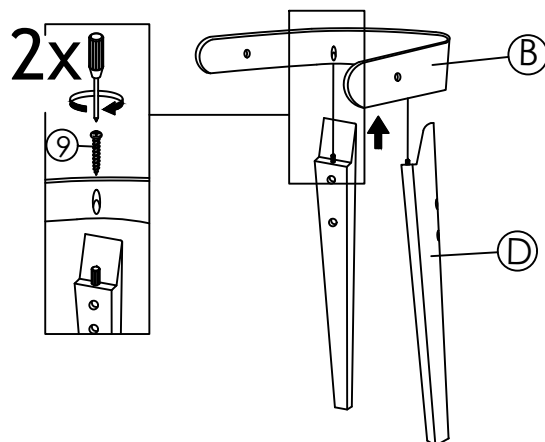

STEP 2/ΒΗΜΑ 2:

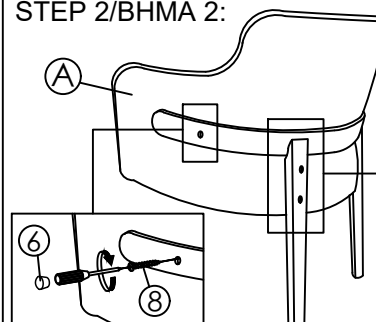

REMARK:

2.1 & 2.2 : FIXED SCREW IN HOLE (UN-FULLY TIGHTEN)/ΣΤΕΡΕΩΜΕΝΗ ΒΙΔΑ ΣΤΗΝ ΟΠΗ (ΟΧΙ ΠΛΗΡΩΣ ΒΙΔΩΜΕΝΗ)

2.3 & 2.4 : TIGHTEN SCREW IN HOLE

2.1 :

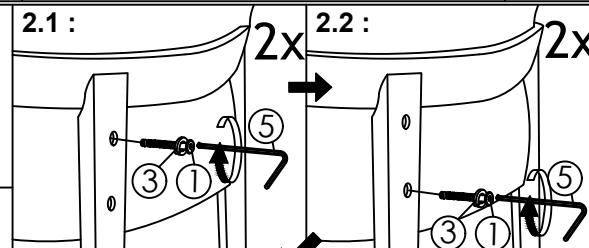

2.2 :

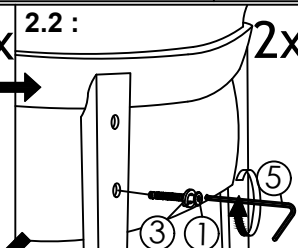

2.3 :

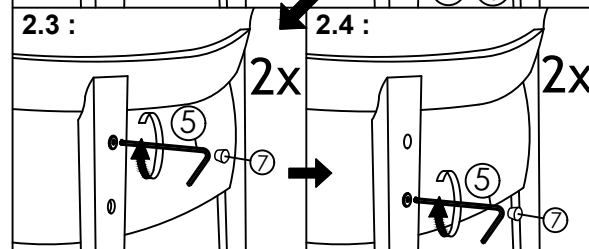

2.4 :

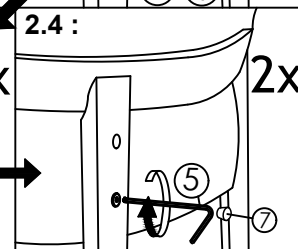

STEP 3/ΒΗΜΑ 3:

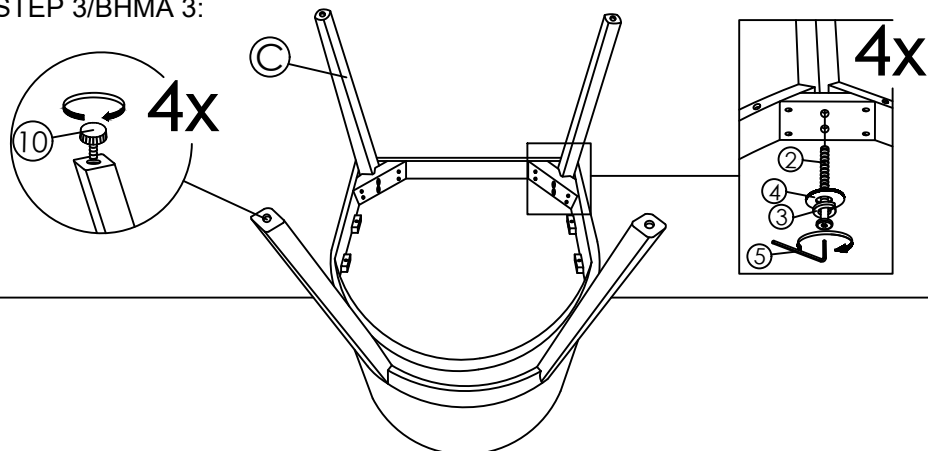

STEP 4/ΒΗΜΑ 4:

