

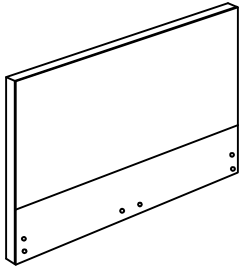

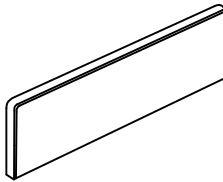

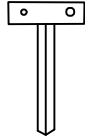

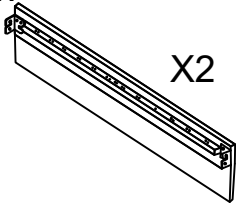



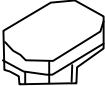

<p>1.</p> 	<p>2.</p> 	<p>3.</p> <p>X2</p> 
<p>4.</p> <p>X2</p> 	<p>5.</p> <p>X1</p> 	<p>6.</p> <p>X2</p> <p>6</p> 
<p>7.</p> <p>X13</p> 	<p>8.</p> <p>X26</p> 	<p>9.</p> <p>X4</p> 
<p>ÇOED T ÌEH€ { { EFG</p> 	<p>ÇÓDÁ T ÌEHÍ { { EFG</p> 	<p>ÇÔDÁ T ÌEI</p> 
<p>(D)X8</p> 	<p>(E)X8</p> 	<p>(F)X1</p> 
<p>(G)X1</p> 		

STEP 1/ΒΗΜΑ 1) FIXING LEGS TO HEADBOARD AND FOOTBOARD/  
 ΤΟΠΟΘΕΤΗΣΗ ΠΟΔΙΩΝ ΣΤΟ ΚΕΦΑΛΑΡΙ ΚΑΙ  
 ΣΤΟ ΠΟΔΑΡΙΚΟ

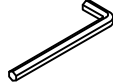
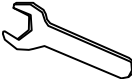
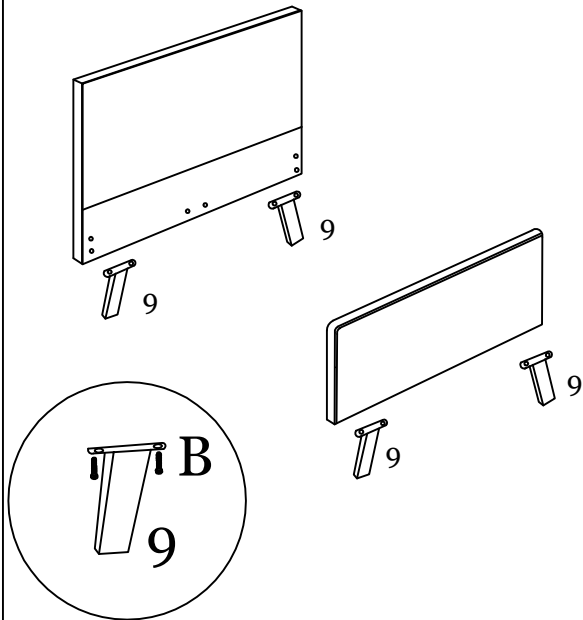

STEP 2/ΒΗΜΑ 2) FIXING SUPPORT LEGS TO CENTRE SUPPORT BAR/  
 ΒΙΔΩΜΑ ΠΟΔΙΩΝ ΣΤΗΡΙΞΗΣ ΣΤΗΝ  
 ΚΕΝΤΡΙΚΗ ΤΡΑΒΕΡΣΑ

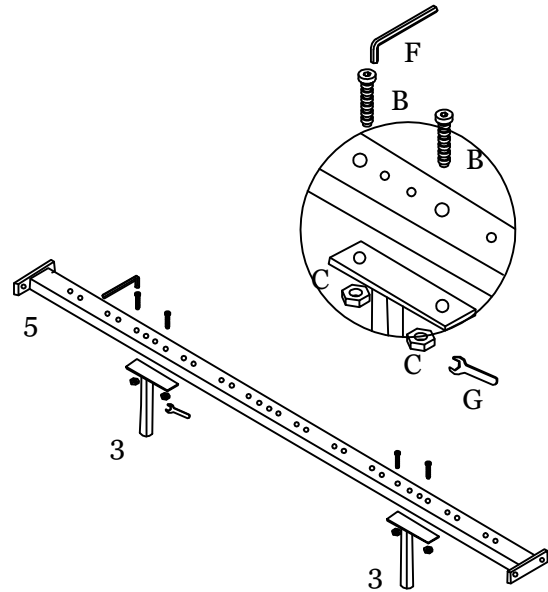

STEP 3/ΒΗΜΑ 3) FIXING SIDE RAILS AND  
 CENTRE SUPPORT BAR TO HEADBOARD AND  
 FOOTBOARD/ΒΙΔΩΜΑ ΠΛΑΙΝΙΩΝ ΤΡΑΒΕΡΣΩΝ &  
 ΚΕΝΤΡΙΚΗΣ ΤΡΑΒΕΡΣΑΣ ΣΤΟ ΚΕΦΑΛΑΡΙ ΚΑΙ  
 ΣΤΟ ΠΟΔΑΡΙΚΟ

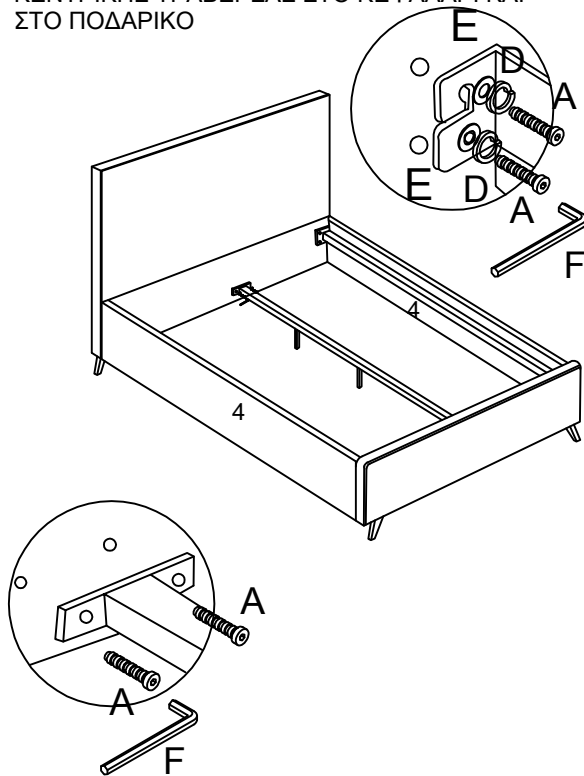

STEP 4/ΒΗΜΑ 4) FIXING PLASTIC CAPS AND  
 SLATS/ΤΟΠΟΘΕΤΗΣΗ ΤΩΝ ΠΛΑΣΤΙΚΩΝ ΚΑΙ ΤΩΝ  
 ΤΑΒΛΩΝ

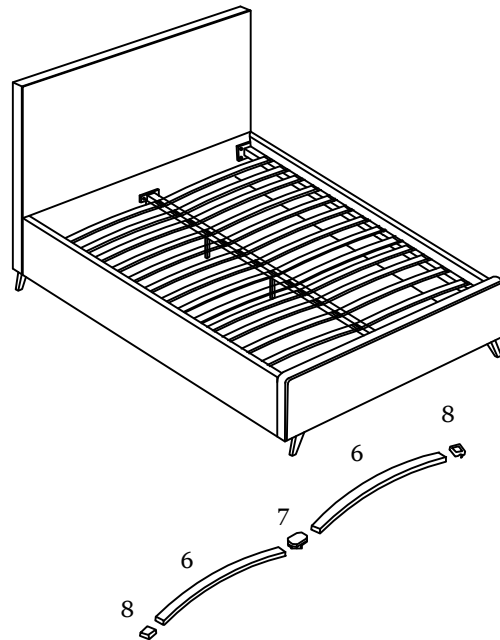

## Οδηγίες Συναρμολόγησης & Καλής χρήσης

### **ΠΡΟΣΟΧΗ:**

- Πριν ξεκινήσετε την συναρμολόγηση του προϊόντος, βεβαιωθείτε ότι υπάρχουν όλα τα στοιχεία συναρμολόγησης.
- Μην πετάξετε τις συσκευασίες πριν ολοκληρώσετε την συναρμολόγηση του προϊόντος.
- Όταν συναρμολογείτε το κρεβάτι θα πρέπει να υπάρχει κενό ανάμεσα στα πόδια και το πάτωμα 3mm. Τα πόδια θα ακουμπήσουν στο πάτωμα μόνο όταν υπάρξει βάρος πάνω στο κρεβάτι.
- Να μην σύρετε το κρεβάτι μαζί με το στρώμα. Επίσης να μην το σύρετε πάνω σε χαλί ή άλλη τραχεία επιφάνεια. Αν χρειαστεί να μετακινήσετε το κρεβάτι, αφαιρέστε πρώτα το στρώμα και ύστερα σηκώστε το για να το μετακινήσετε.

## Assembly Instructions & Good use

### **ATTENTION:**

- Before you start assembling the product, make sure that there are all the necessary components for the assembly.
- Do not throw away the cartons of the product before you complete the assembly.
- When assembling the bed, there should be a gap between the support legs and the floor of 3mm. The feet will only touch the floor when there is weight on the bed.
- Do not drag the bed with the mattress on. Also, do not slide it on a carpet or other rough surface. If you need to move the bed, you need to take the mattress off of it and then lift the bed to move it.

## Инструкция за сглобяване и правилна употреба

### **Внимание:**

- Преди да започнете да сглобявате продукта, проверете дали всички необходими елементи за сглобяването са налични.
- Не изхвърляйте кашоните на продукта преди да го сглобите.
- Трябва да има 3 мм. разстояние между краката и пода, когато сглобявате леглото. Краката се допират в земята, когато има допълнителна тежест върху леглото.
- Не местете леглото, докато матракът е върху него. Също така не го плъзгайте по паркетни или твърди подови настилки. Ако се налага да местите леглото, първо махнете матрака и след това повдигнете леглото, за да го преместите.