

# ΣΥΡΤΑΡΙΕΡΑ BLOCK / DRAWER BLOCK



1



2

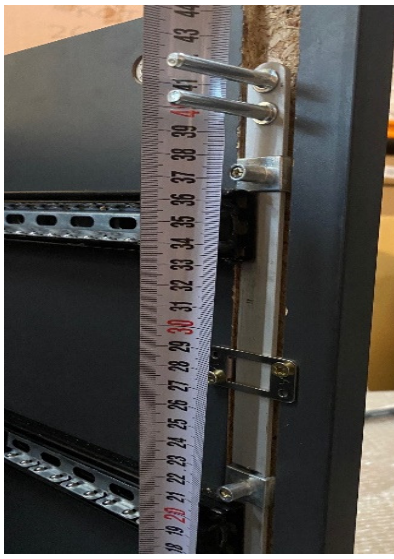

3



4

Τοποθέτηση μπάρας κλειδώματος (μέρος L) / Placement locking bar (part L)



Συρτάρι / Drawer



Κλείδωμα / Key Lock  
Αριστερά κλειδώνει / Lock to the left



Ξεκλείδωμα / Key unlock  
Δεξιά ξεκλειδώνει / Unlock to the right



Ρόδα / Weel 1



Ρόδα / Weel 2



Ρόδα / Weel 3

Η ρόδα κατά την περιστροφή της δεν πρέπει να προεξέχει του επίπλου / The wheel during its rotation must not protrude the drawer.



01 03	454x450=2	1/1
02	454x364	1/1
04	450x400	1/1
05	470x400	1/1
06 07	306x80=6	1/1
08 09	400x80=6	1/1
10	400x338=3	1/1

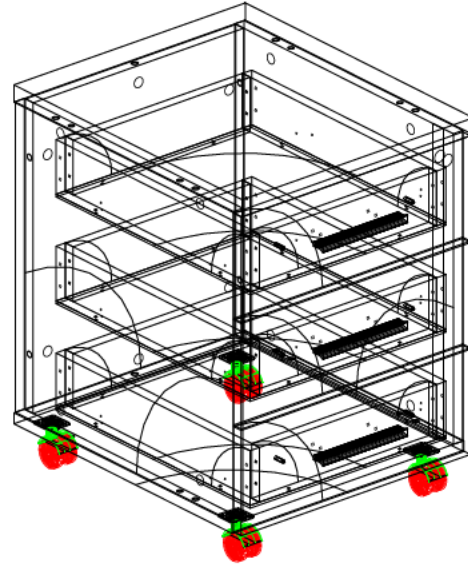

X 14	X 14	X 8	X 4	X 78	X 3	X 6	X 1	X 6	X 24	X 1	X 6
		8x30mm		M3. 5x14mm		M4x22mm		M3. 5x20mm	M4x30mm		

**-ΠΡΟΕΤΟΙΜΑΣΙΑ - PREPARATION**

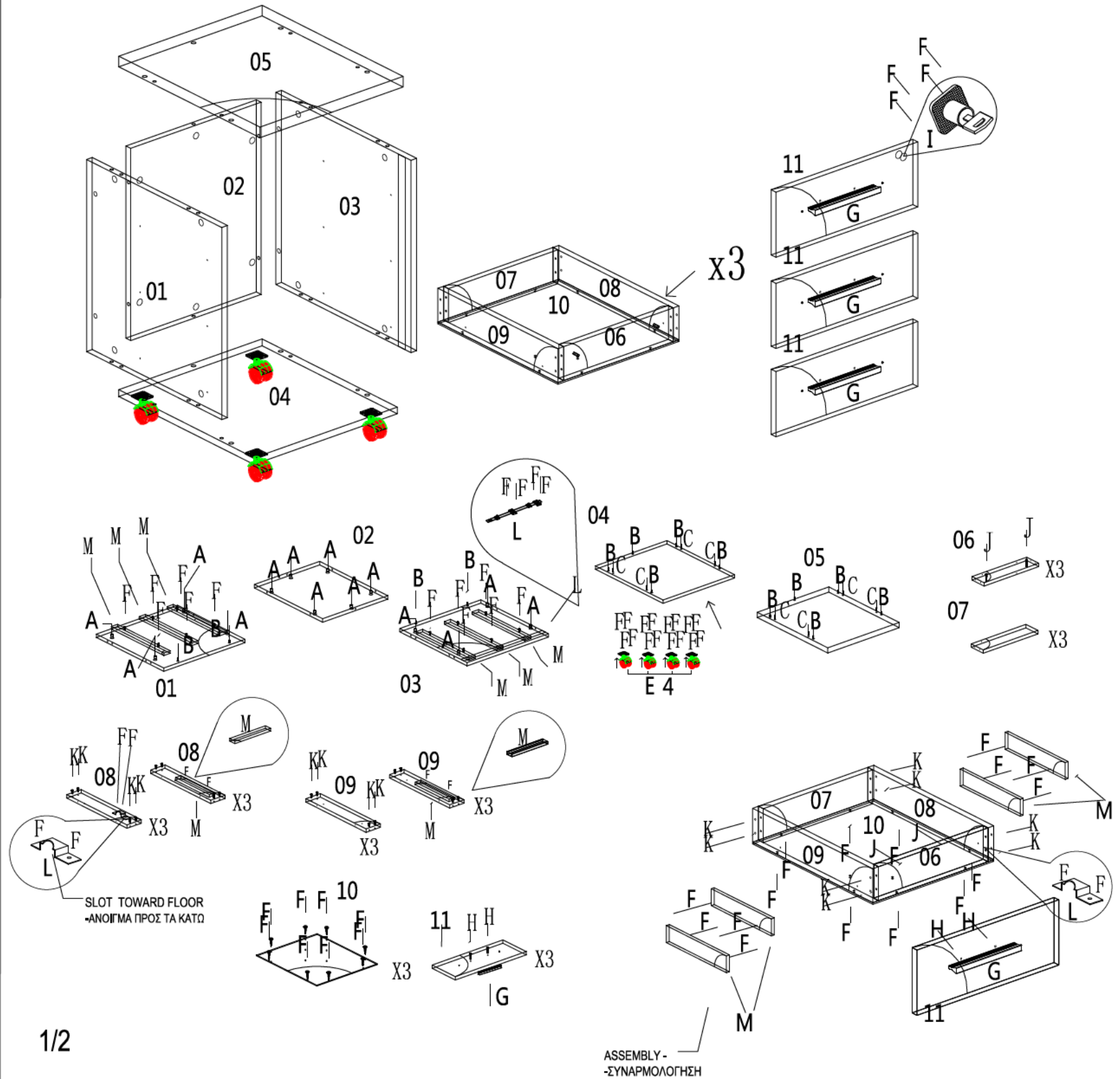

-ΣΥΝΑΡΜΟΛΟΓΗΣΗ - ASSEMBLY

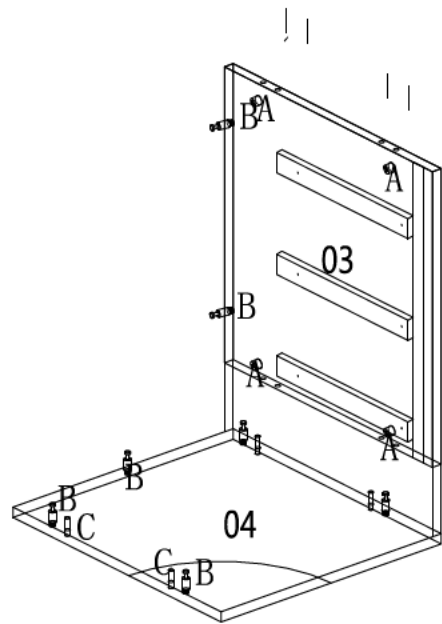

BHMA STEP 1

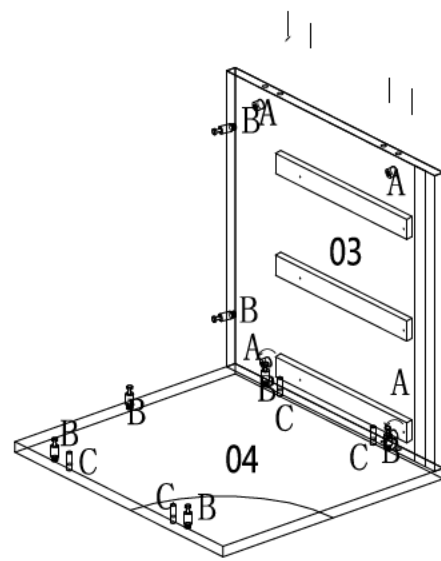

BHMA STEP 2

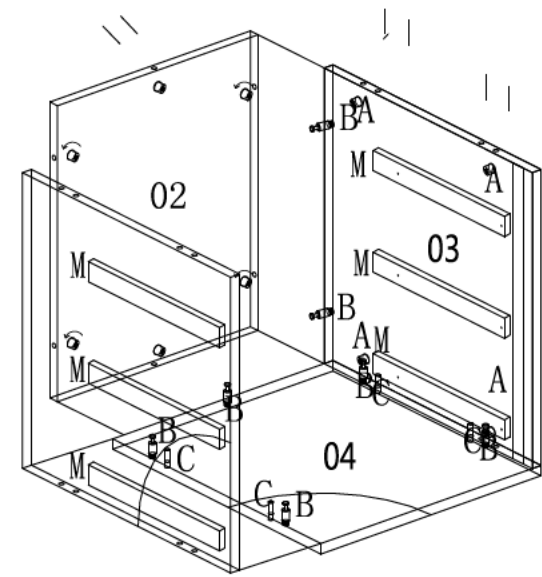

BHMA STEP 3

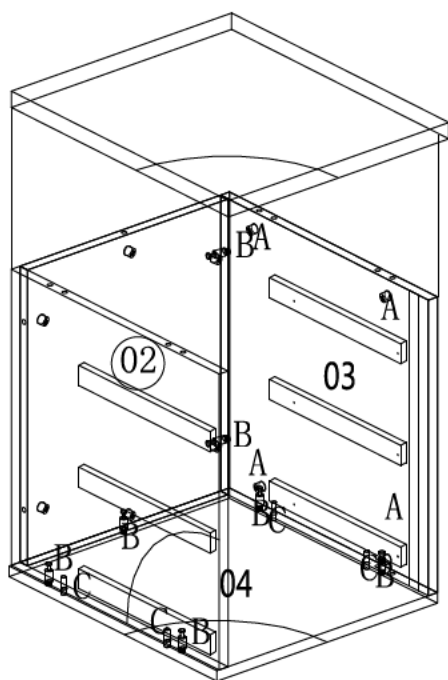

BHMA STEP 4

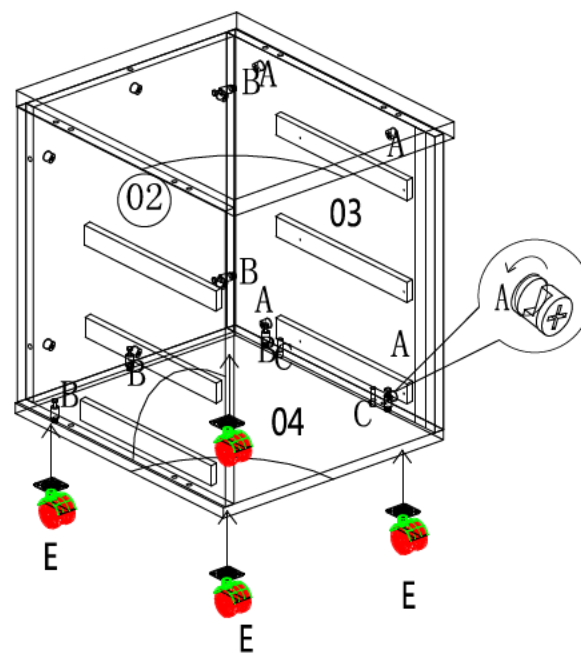

BHMA STEP 5

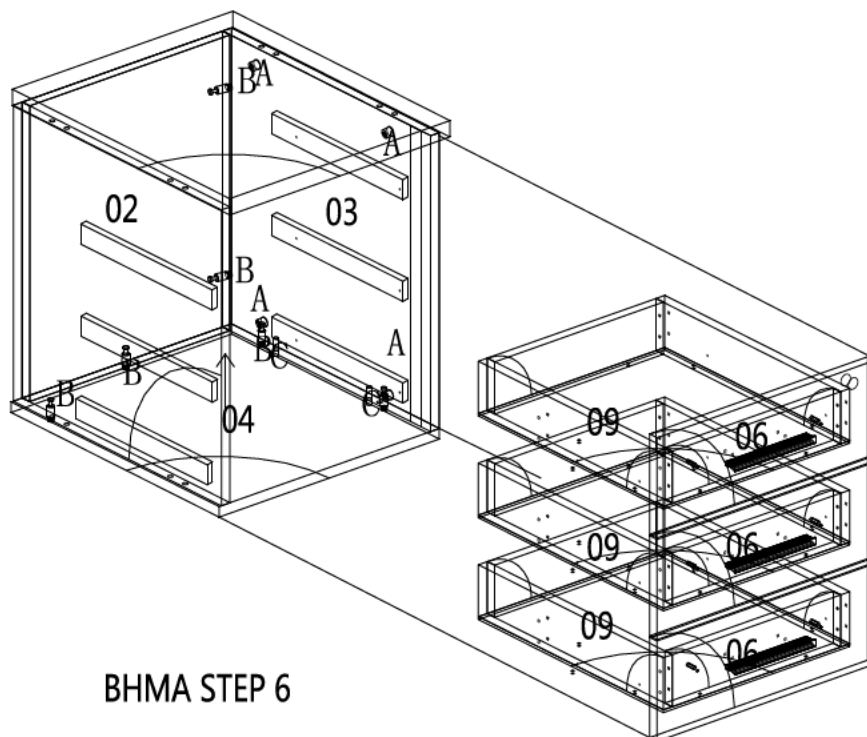

BHMA STEP 6

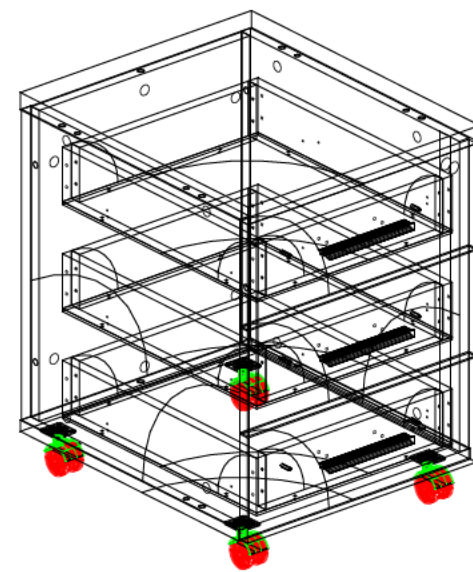

BHMA STEP 7